



ESCALADE

2013  
CADILLAC ESCALADE



ESCALADE FAMILY

ESCALADE

HYBRID

ESV

EXT

PERFORMANCE

SAFETY TECHNOLOGY

COLLECTIONS

COLOR

WHEELS

SPECS

*HOW ICONS*

*BECOME ICONS.*

Maybe it's the fact that they come with a larger-than-life presence. Or that they're renowned the world over. But to really define what creates an icon, you have to dig deeper. And that's where the Escalade cements its status. By any measure, it continues to redefine the category.



*ESCALADE LUXURY COLLECTION / Black Raven*



*ESCALADE HYBRID*



*ESCALADE EXT*



*ESCALADE ESV*

**GET THE LATEST FROM CADILLAC**

Get news, events, info and updates—  
all in a monthly e-mail.

**SIGN UP »**

ESCALADE FAMILY

ESCALADE

HYBRID

ESV

EXT

PERFORMANCE

SAFETY TECHNOLOGY

COLLECTIONS

COLOR

WHEELS

SPECS

From its dramatic grille to its vertical LED taillamps, the Escalade is iconic in every detail. Its commanding presence is backed by a 6.2L V8 engine that delivers tremendous yet refined power. A comfortable ride is ensured by available Magnetic Ride Control—a class-exclusive suspension system. No matter which Escalade model you choose—Escalade, ESV or EXT—you're assured of exceptional towing capability. Add in the availability of All-Wheel Drive,<sup>1</sup> and you have total driving confidence. Inside, supple surroundings are highlighted by leather trim, burled accents and spacious seating for up to eight in Escalade and ESV models. It all adds up to an SUV experience unlike any other.



#### **ADAPTIVE REMOTE START**

From up to half a football field away, the Escalade engine can be started and the interior heated or cooled, depending on the outside temperature.

# LUXURY AND CAPABILITY

ON A GRAND SCALE.



ESCALADE FAMILY

ESCALADE

HYBRID

ESV

EXT

PERFORMANCE

SAFETY TECHNOLOGY

COLLECTIONS

COLOR

WHEELS

SPECS



*ESCALADE PLATINUM EDITION / White Diamond Tricoat*



# ESCALADE

ESCALADE FAMILY

ESCALADE

HYBRID

ESV

EXT

PERFORMANCE

SAFETY TECHNOLOGY

COLLECTIONS

COLOR

WHEELS

SPECS



## *EXTERIOR DESIGN*

CLICK THE HOTSPOTS FOR FEATURE DETAILS

### **Distinctive Front Grille**

The Escalade front end makes a bold statement with its Cadillac signature grille emblazoned with the Wreath and Crest.

### **22" Dual 7-Spoke Wheels**

The available 22" dual 7-spoke chromed aluminum wheels include P285/45R22 all-season tires and lend added presence to an already impressive stance.

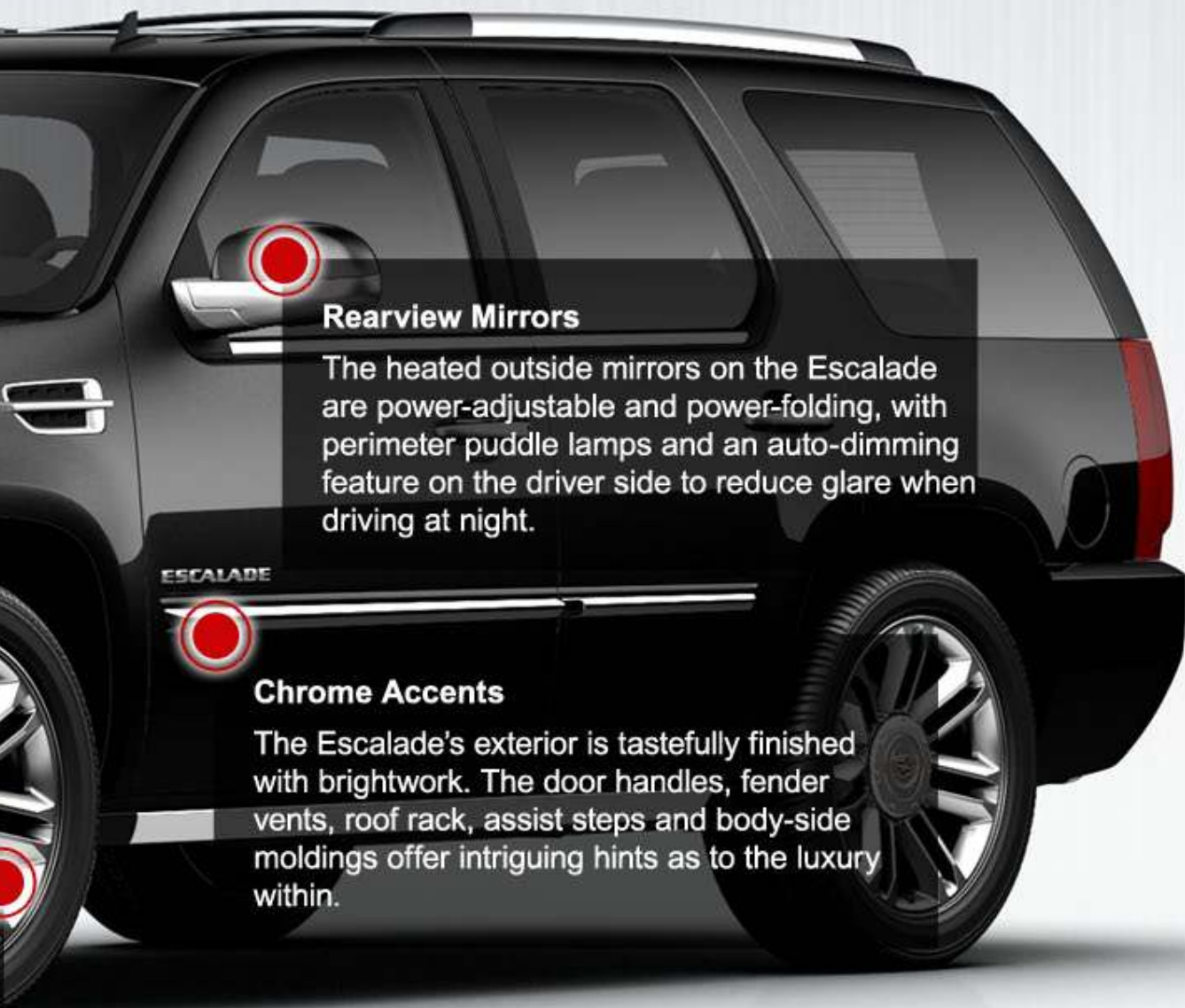

### **Rearview Mirrors**

The heated outside mirrors on the Escalade are power-adjustable and power-folding, with perimeter puddle lamps and an auto-dimming feature on the driver side to reduce glare when driving at night.

### **Chrome Accents**

The Escalade's exterior is tastefully finished with brightwork. The door handles, fender vents, roof rack, assist steps and body-side moldings offer intriguing hints as to the luxury within.

## INTERIOR DESIGN

CLICK THE HOTSPOTS FOR FEATURE DETAILS



### Heated Steering Wheel

Added luxury you can truly feel. With the press of a button, the available heated steering wheel quickly warms to the touch to eliminate the need for gloves while driving on a cold day.



### French-Stitched Leather

14-way power-adjustable, heated/cooled supple leather-trimmed front seats with memory settings and elegant French-stitched seams.



### Bose® 5.1 Surround Sound System

Ten ideally placed speakers deliver a smooth, rich sound, no matter what you're listening to.



### Fine Finishes

The stunning interior is adorned in elegant brushed-aluminum accents, polished chrome and tastefully selected burl wood trim.



### Automatic Climate Control

Tri-zone climate control allows driver, front passenger and rear passengers to individually select their own temperature settings with up to a 30-degree difference in each individual zone.

THE ELLI AND EDY THE BROAD



WHERE  
EFFICIENCY, POWER AND LUXURY  
COME TOGETHER. BRILLIANTLY.

ESCALADE HYBRID PLATINUM EDITION / White Diamond Tricoat



From the most acclaimed luxury SUV ever comes the intelligently efficient Escalade Hybrid. Seamlessly combining an advanced hybrid system and Active Fuel Management, the Escalade Hybrid uses two types of power: energy created by its gas engine and electricity generated by electric motors. The result? The best fuel economy in its class<sup>1</sup> with an EPA-estimated 20 mpg city/23 mpg highway, all while delivering the sophistication and refinement that has made Escalade iconic.

1. Based on the 2012 Ward's Large Luxury Utility segment.

## ***HYBRID SYSTEM***

The Escalade Hybrid provides a perfect balance of performance and efficiency and offers an EPA-estimated 20 MPG in the city and 23 MPG on the highway. The Hybrid is so smart that it can run on electric power, gasoline power or both, and will automatically choose the most efficient mode to use depending on your speed, payload and whether you need power to pass or trailer.

### **SEE HOW IT WORKS**

1 2 3 4 **5**

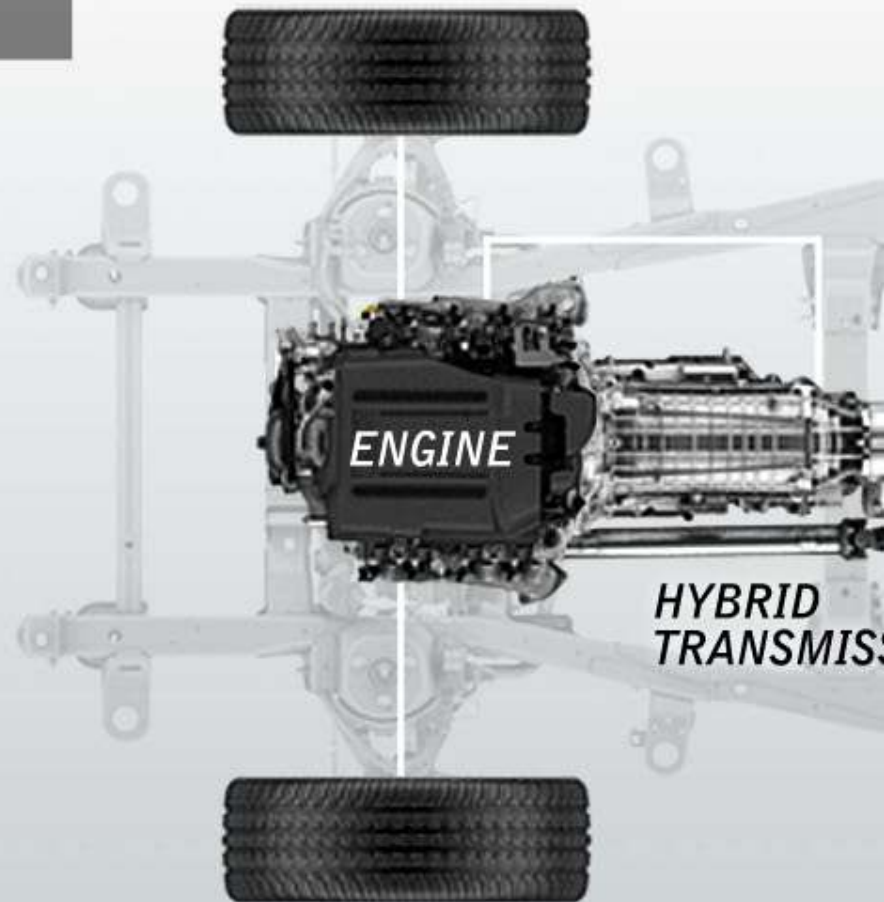

#### **1. Auto Stop (engine off)**

While stopped, the engine may shut off

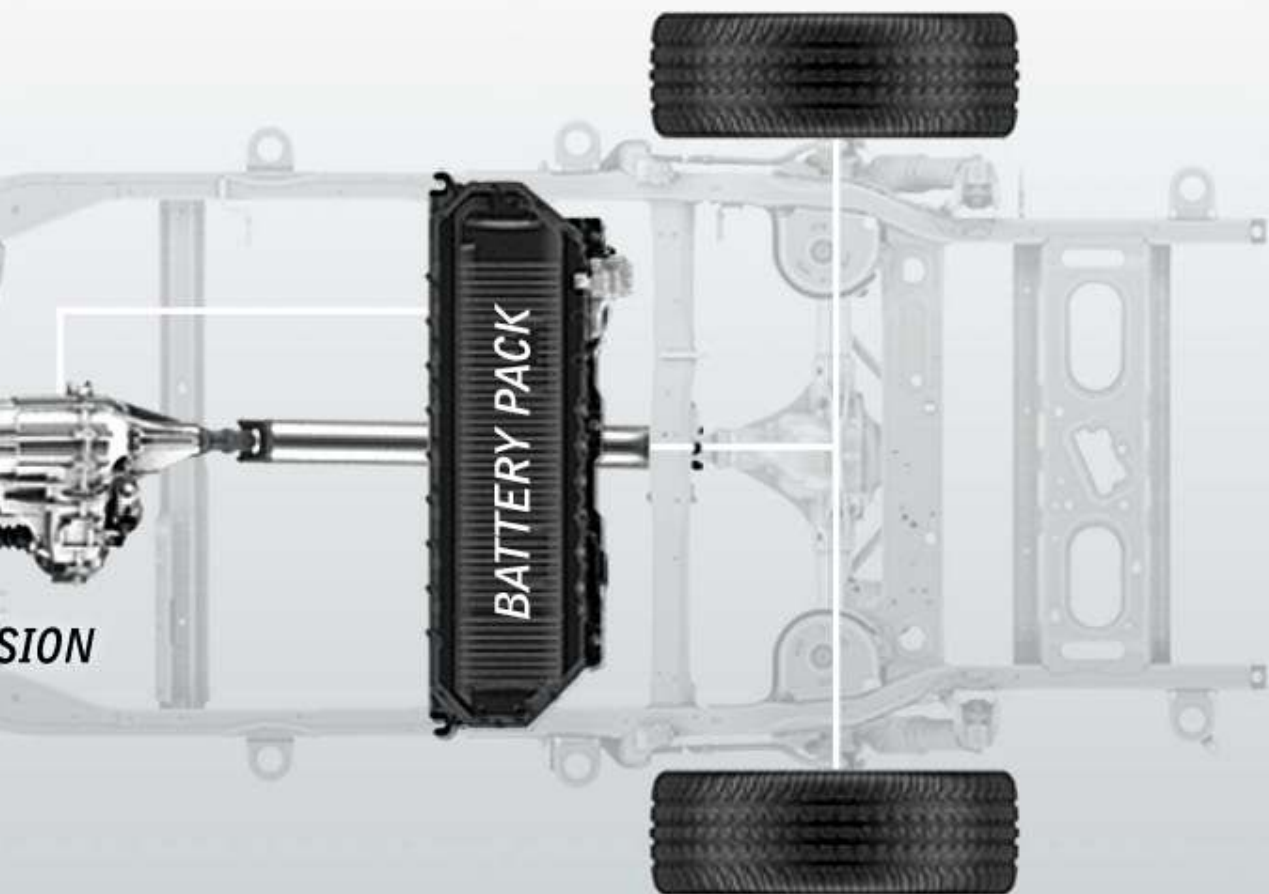

SION

to conserve fuel, then seamlessly restart when you accelerate.





*ESCALADE ESV PREMIUM COLLECTION / Black Raven*



# ESCALADE ESV

ESCALADE FAMILY

ESCALADE

HYBRID

**ESV**

EXT

PERFORMANCE

SAFETY TECHNOLOGY

COLLECTIONS

COLOR

WHEELS

SPECS



ESCALADE ESV PREMIUM COLLECTION / Black Raven

# MORE SPACE. MORE CAPABILITY.

IN OTHER WORDS, MORE ESCALADE.



The Escalade ESV's extended wheelbase adds length (20" longer than the Escalade) that gives it spacious seating for up to eight adults and even more cargo<sup>1</sup> capacity. Navigating is made easier with the rearview backup camera display, while the available Side Blind Zone Alert<sup>2</sup> built into the exterior rearview mirrors alerts you when another vehicle has entered your blind spot. For those times when you need more space, the ESV delivers full-size accommodations along with the luxury for which Escalade is famous.



## POWER LIFTGATE

The power liftgate can be opened or closed using either the key fob or a switch in the overhead console. Additional controls on the liftgate also allow one-finger operation from the back.

1. Cargo and load capacity limited by weight and distribution. 2. Before making a lane change, always check the SBZA display and the side and inside mirrors, look over your shoulder for vehicles and hazards, and activate your turn signal.

WHERE LUXURY REVEALS  
ITS PRACTICAL SIDE.



**EASE OF ENTRY**

The simple touch of a button sends the second row into motion, folding the seats forward, making it easier for rear passengers to enter.



**THIRD-ROW SEATS REMOVED**

For a best-in-class 137.4 cu. ft. of cargo room,<sup>1</sup> remove the third-row seat and simply fold the second-row seats (image shown with second-row seats upright).



**ALL**

On f  
conf  
adv

Gla  
only  
to a  
the  
30 c  
row

1. Cargo and load capacity limited by weight and distribution.



## SEATS IN PLACE

Top of seating for up to eight (seven-passenger configuration shown), the ESV offers the added advantage of 45.8 cu. ft. of space behind the third row.

Once inside the Escalade ESV, and you'll admire not only its leather and burled accents, but also its ability to accommodate just about anything. In fact, it offers the most cargo room in its class—137.4 cu. ft., almost 50 cu. ft. more than Escalade. The reclining second-row bucket seats have heated seat cushions and

an available power release function that folds them forward. The third row features 50/50 split-bench seats that adjust individually and can be folded, tumbled forward or totally removed, depending on your needs. And, thanks to the power liftgate, accessing all that space is effortless.



ESCALADE EXT PREMIUM COLLECTION / *Black Raven*



# ESCALADE EXT

ESCALADE FAMILY

ESCALADE

HYBRID

ESV

**EXT**

PERFORMANCE

SAFETY TECHNOLOGY

COLLECTIONS

COLOR

WHEELS

SPECS





ESCALADE EXT PREMIUM COLLECTION / Black Raven

The Escalade EXT offers all the luxury of the Escalade with the capability of hauling a piece of furniture or picking up a motorcycle. In an instant, you can access an 8' bed and 101 cu. ft.<sup>1</sup> of covered, secure cargo space just by folding the Midgate<sup>®</sup> panel forward. There's also a tonneau cover that locks to help keep cargo secure and protected from

the elements. Inside, the luxurious amenities begin with 14-way power-adjustable front seats with leather seating surfaces and a split-folding rear seats for added versatility. Navigation<sup>2</sup> with an 8" touch screen that includes voice recognition and a premium Bose<sup>®</sup> Cabin Surround<sup>®</sup> sound system that delivers smooth, rich sound.

VERSATILITY IS PERHAPS THE

GREATEST LUXURY OF ALL.



### **MIDGATE® PANEL**

Flexibility at your fingertips. Fold the Midgate forward with the rear window in place to create 101 cu. ft.<sup>1</sup> of covered and secure cargo volume.



### **TOP BOX STORAGE**

Keep cargo organized and secure. Top box storage bins are ideal for small, wet or dirty items you don't want inside the vehicle.

1. Cargo and load capacity limited by weight and distribution.

2. Map coverage available in the United States, U.S. Virgin Islands, Puerto Rico and Canada.

## EXTERIOR STYLING

CLICK THE HOTSPOTS FOR FEATURE DETAILS

### Rearview Mirrors

The heated outside mirrors on the Escalade EXT are power-adjustable and power-folding, with perimeter puddle lamps and an auto-dimming feature on the driver side to reduce glare when driving at night.

### Magnetic Ride Control

Intuitive available Magnetic Ride Control reads the road up to 1,000 times per second, giving you an almost instantaneous response to any road surface.



### Cargo Bed

In an instant, you can create an 8' bed just by folding the Midgate<sup>®</sup> panel forward. The well-lit 101 cu. ft.<sup>1</sup> of covered, secure cargo space is complete with a 3-piece tonneau cover and assist handles for easy access.



### All-Wheel Drive

All-Wheel Drive (AWD) features a fixed-torque bias that enhances vehicle stability. Improved traction on any road condition greatly enhances your driving confidence.

1. Cargo and load capacity limited by weight and distribution.

# BRAINS MEET BRAWN

FOR EXHILARATING PERFORMANCE.

In some ways, it defies logic: A full-size luxury SUV that's quicker than the smaller and lighter Mercedes-Benz C300 Sport Sedan. Adding to its formidable presence on the road, the Escalade's 403 HP 6.2L V8 creates a vehicle with immense power at your disposal. Among its fuel-saving features is Variable Valve Timing that controls the valves during intake and exhaust, enabling the engine to operate more efficiently.<sup>1</sup>

Available All-Wheel Drive and a rear locking differential get all 403 HP to the pavement with confidence. Once on your way, available Magnetic Ride Control helps maintain a balanced ride. In the time it takes you to blink, this suspension system has monitored the road 1,000 times. Magnetic particles suspended in a fluid then react to a magnetic field and instantly align to provide the proper damping.

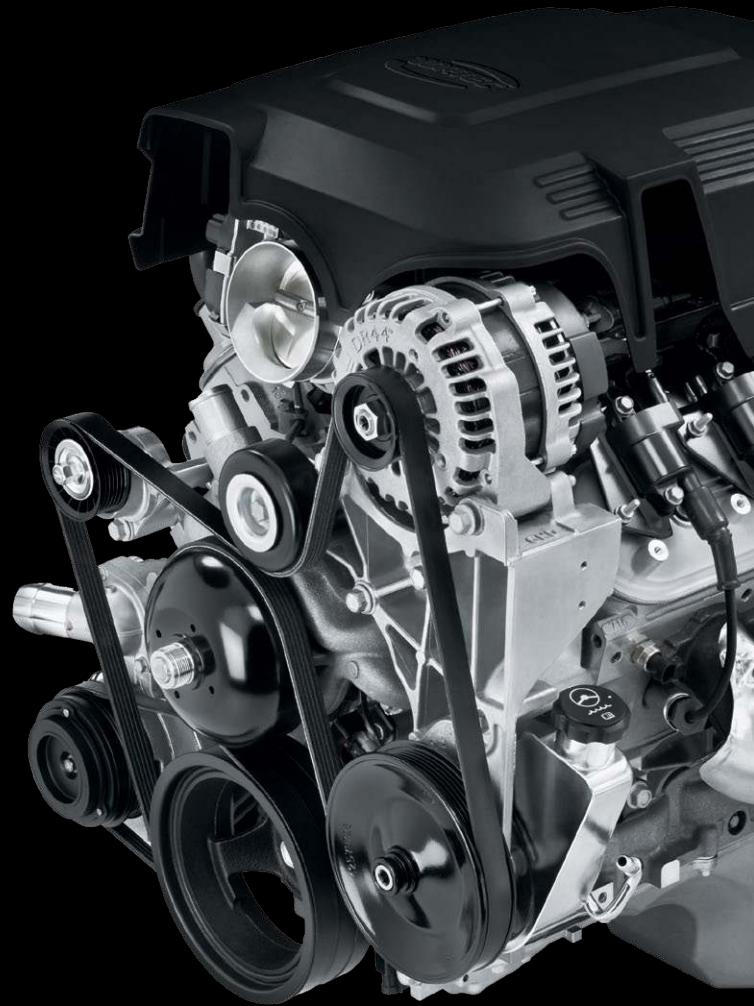

**THE 403 HP 6.2L V8 ENGINE**

1. Escalade RWD: EPA-estimated mpg 14 city / 18 highway. Escalade AWD: EPA-estimated 13 city / 18 highway.

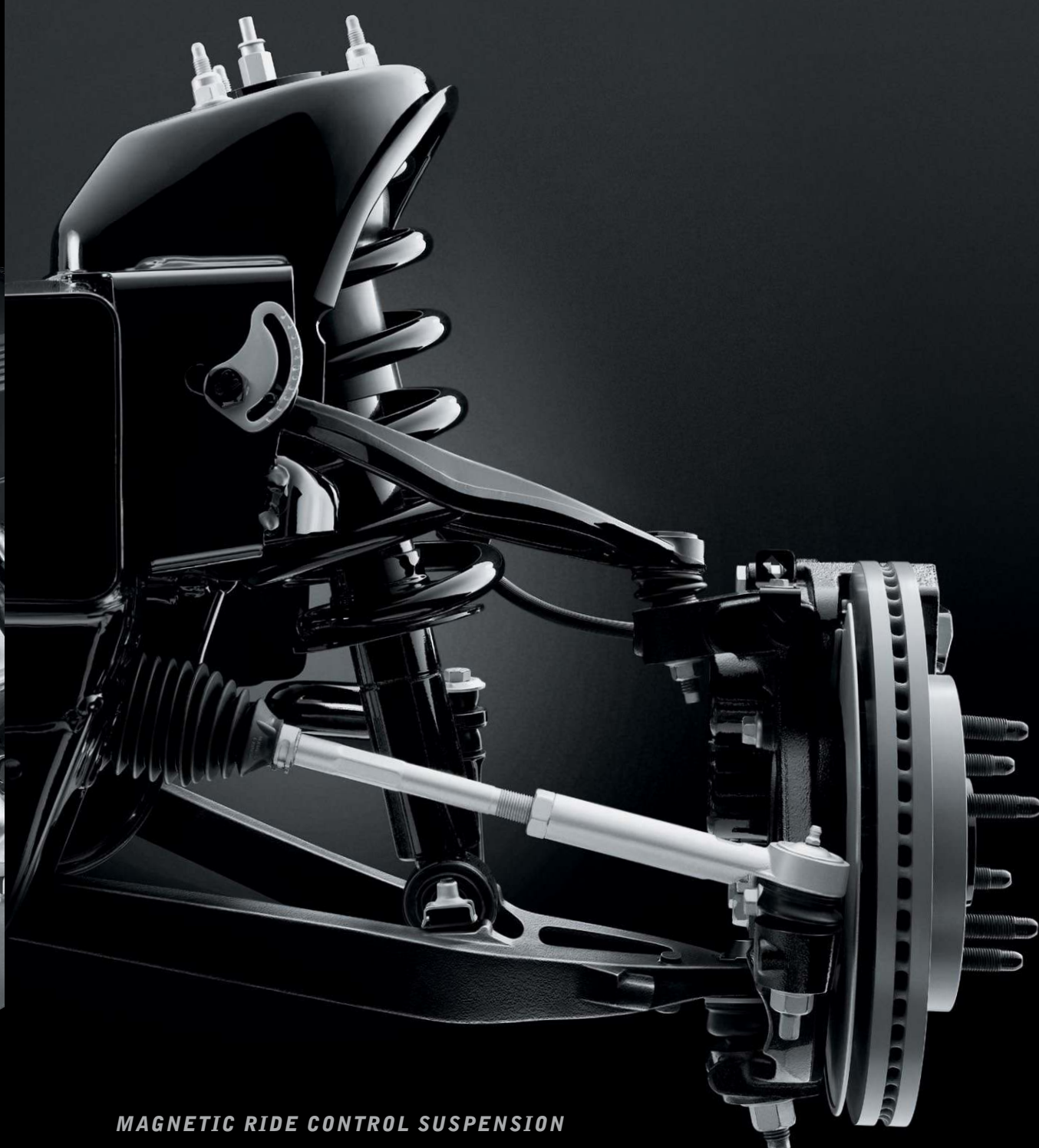

*MAGNETIC RIDE CONTROL SUSPENSION*

## ***MAGNETIC RIDE CONTROL***

Revolutionary Magnetic Ride Control adjusts to changing road conditions in milliseconds, giving you an almost instantaneous response to any road surface.

**CHOOSE ROAD CONDITION**

**SMOOTH »**

**MODERATE »**

**SEVERE »**





ESCALADE FAMILY

ESCALADE

HYBRID

ESV

EXT

**PERFORMANCE**

SAFETY TECHNOLOGY

COLLECTIONS

COLOR

WHEELS

SPECS

AS SEEN ON THE PREMIUM MODEL



*BENEATH ITS POLISHED SHEET METAL RESIDES  
A CHISELED SUIT OF ARMOR.*



1. Always use safety belts and the correct restraint for your child's age and size. Even in vehicles equipped with the Passenger Sensing System, children are safer when properly secured in a rear seat in the appropriate infant, child or booster seat. Never place a rear-facing infant restraint in the front seat of any vehicle equipped with a passenger air bag. See the Owner's Manual and child safety seat instructions for more safety information. 2. Visit [onstar.com](https://onstar.com) for coverage map, details and system limitations. Services vary by model and conditions. OnStar acts as a link to existing emergency service providers.



### **REARVIEW BACKUP CAMERA**

Parking is made easier with the rearview backup camera. It turns on automatically when your Escalade is placed in reverse. It displays a live image of the area behind the vehicle on the navigation screen and includes guiding lines to help you when backing up.

It starts with a protective safety cage constructed with ultra-high-strength steel alloys and other highly advanced materials for exceptional rigidity and strategically placed crumple zones. Then we add preventive safety features like the StabiliTrak Electronic Stability Control System with traction control that's designed to improve vehicle stability on most road surfaces, especially during emergency maneuvers. A sophisticated antilock braking system (ABS) and Electronic Braking Force Distribution help balance stopping power between the front and rear brakes.

In addition to eight standard airbags,<sup>1</sup> there's also the confidence that comes with front safety belt pretensioners that lock the safety belt to help better secure occupants during a crash. Additionally, rollover mitigation sensors that detect a rollover trigger the pretensioners when air bags are opening.

For added peace of mind, there's OnStar<sup>®2</sup> with Automatic Crash Response. In most crashes, built-in sensors in your vehicle can automatically send an alert to an OnStar Advisor, who is immediately connected into your car to help.



## ***SIDE BLIND ZONE ALERT***

Side Blind Zone Alert<sup>1</sup> lets drivers know when something is in their blind spot. Warning lights in the mirrors alert the driver to potential danger. Wish you had an extra set of eyes? Now you do.

### **EXPERIENCE SIDE BLIND ZONE ALERT**

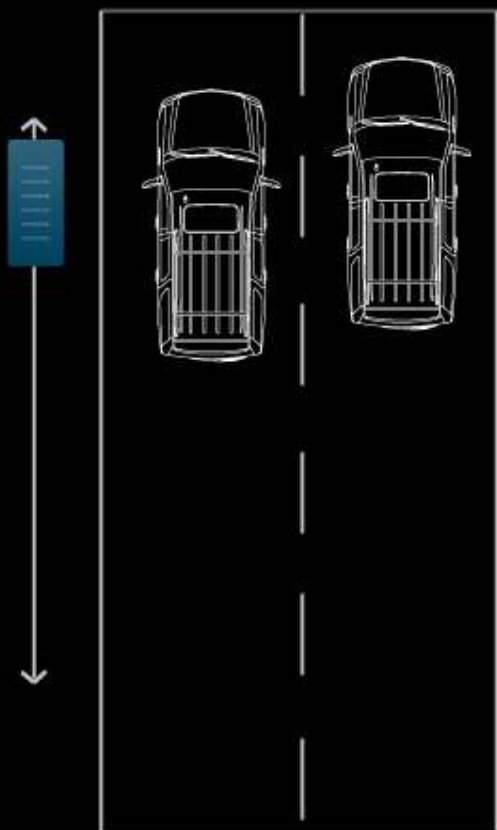

1. Before making a lane change, always check the SBZA display, check the side and inside rear mirrors, look over your shoulder for vehicles and hazards, and start the turn signal.



ESCALADE FAMILY

ESCALADE

HYBRID

ESV

EXT

PERFORMANCE

**SAFETY TECHNOLOGY**

COLLECTIONS

COLOR

WHEELS

SPECS

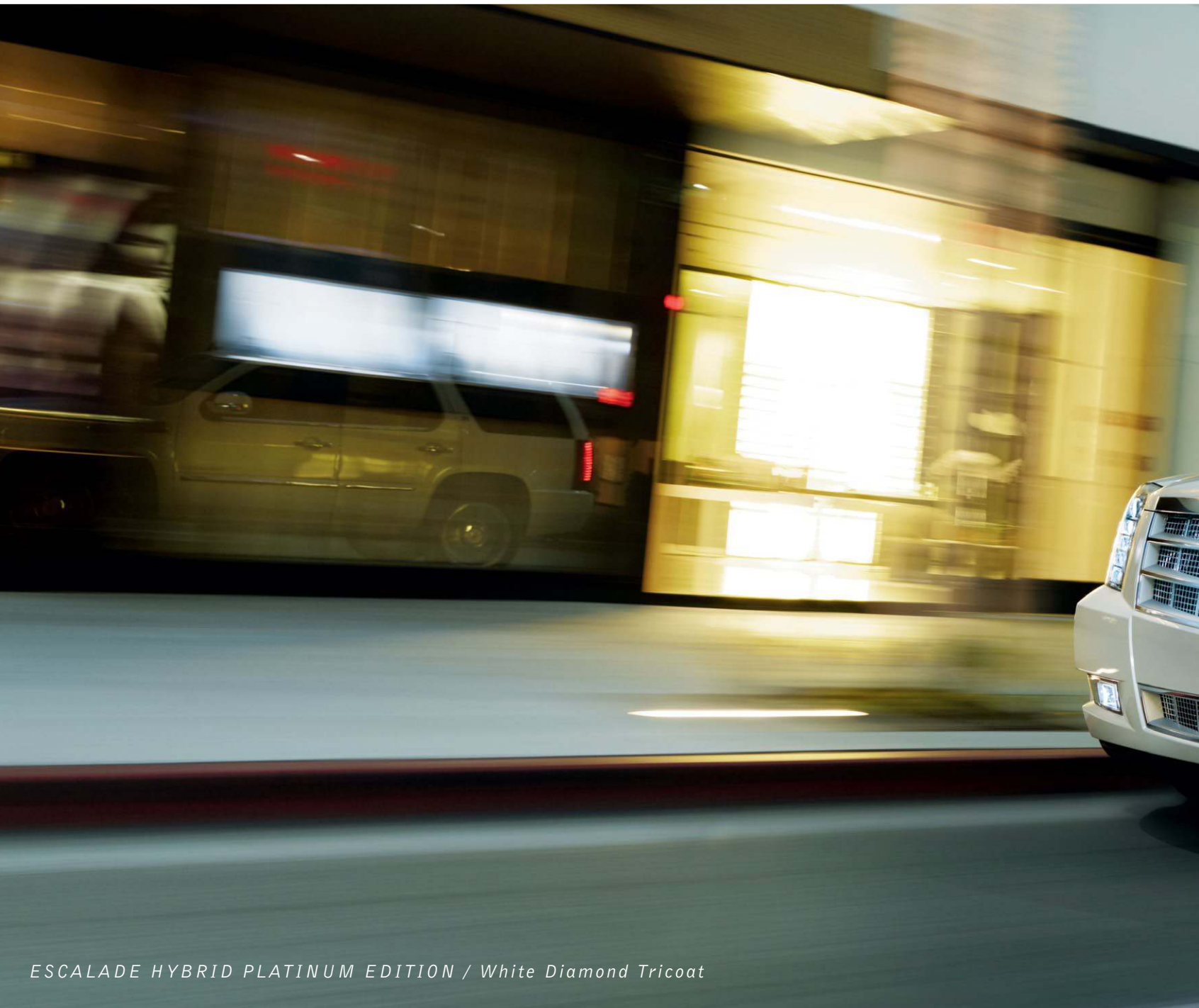

*ESCALADE HYBRID PLATINUM EDITION / White Diamond Tricoat*



# COLLECTIONS

ESCALADE FAMILY

ESCALADE

HYBRID

ESV

EXT

PERFORMANCE

SAFETY TECHNOLOGY

COLLECTIONS

COLOR

WHEELS

SPECS



### ***PLATINUM INTERIOR***

The Platinum Edition is filled with impressive amenities. From heated and cooled front seats to a premium 10-speaker Bose® Cabin Surround® sound system and a wood-trimmed heated steering wheel, it's the ultimate expression of Escalade luxury.

PLATINUM EDITION:

EVEN THE PINNACLE HAS  
A HIGH POINT.



**OLIVE ASH AND BURLED WALNUT WOOD TRIM**



**ANILINE LEATHER SEATING SURFACES**

We considered every detail when it came to the Platinum Edition. Experience the richness of its glove-soft Aniline leather that wraps heated and cooled front seats. The fine craftsmanship is also evident in the leather-wrapped instrument panel top pad and upper door trim, as well as the distinctive grain in the olive ash and burled walnut wood trim with decorative inlays. We've even considered your favorite beverages and provided heated and cooled cupholders. The Platinum Edition is the most luxurious Escalade we have ever made. And, given our history, that's a considerable achievement.

ESCALADE FAMILY

ESCALADE

HYBRID

ESV

EXT

PERFORMANCE

SAFETY TECHNOLOGY

COLLECTIONS

COLOR

WHEELS

SPECS





***EXCLUSIVE BODY-COLOR GRILLE***

The bold, iconic front is accented with a grille that seamlessly matches the exterior color for a sleek and seamless appearance.

PREMIUM EDITION:

# SAY EVERYTHING

WITHOUT SAYING ANYTHING.



**INTEGRATED DUAL-OUTLET EXHAUST**



**22" WHEELS**

With the available Premium Collection, the Escalade makes a powerful statement both in its styling and upscale appointments. Outside, monochromatic exterior accents and integrated dual-exhaust outlets lend a distinct appearance. Inside, a Rear Seat Entertainment system with a roof-mounted 8" screen (two screens in ESV models) and provides rear-seat passengers with hours of entertainment. This Collection also features Magnetic Ride Control suspension to help provide a smooth, controlled ride. To top it off, 7-spoke 22" ultra-bright machined-finish wheels and the convenience of power-retractable assist steps further complement what is already an impressive package.

ESCALADE FAMILY

ESCALADE

HYBRID

ESV

EXT

PERFORMANCE

SAFETY TECHNOLOGY

COLLECTIONS

COLOR

WHEELS

SPECS



### **DRIVER-FOCUSED INTERIOR**

The power-tilt adjustable steering wheel features integrated controls for audio and cruise. Both driver and passenger seats are 14-way power adjustable, and the driver's seat memory function stores the preferred settings for up to two drivers.

LUXURY COLLECTION:

BECAUSE THE SUBTLE DETAILS MAKE  
THE BOLDEST STATEMENT.



**SECOND-ROW POWER-RELEASE SEATS**



**INTELLIBEAM HEADLAMPS**

Step inside Escalade with the available Luxury Collection, and you'll find a beautifully appointed cabin with amenities like a power-adjustable, wood-trimmed heated steering wheel—a welcome feature on a chilly morning. You'll also appreciate the convenience of second-row power-release seats that make it easier for rear passengers to enter. There's also revolutionary Magnetic Ride Control suspension that helps smooth out the ride. Complementing the Escalade's commanding presence are striking 22" chromed aluminum wheels. And overhead, there's a power-sliding sunroof that opens to the heavens above.

ESCALADE FAMILY

ESCALADE

HYBRID

ESV

EXT

PERFORMANCE

SAFETY TECHNOLOGY

COLLECTIONS

COLOR

WHEELS

SPECS

CUSTOM



RADIANT SILVER  
METALLIC

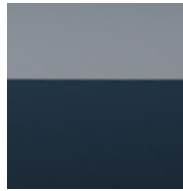

SAPPHIRE BLUE  
METALLIC<sup>1</sup>



WHITE DIAMOND  
TRICOAT<sup>2</sup>



MOCHA STEEL  
METALLIC<sup>3</sup>



SILVER COAST  
METALLIC<sup>3</sup>

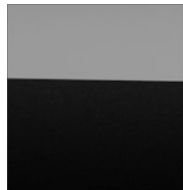

BLACK RAVEN



CRYSTAL RED  
TINTCOAT<sup>2,3</sup>

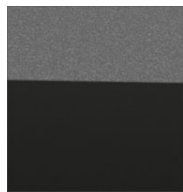

BLACK ICE  
METALLIC<sup>2,3</sup>



# SIZE YOUR *ESCALADE EXTERIOR*

[BUILD YOUR OWN >>](#)

[LOCATE A DEALER >>](#)



## *PAINT FINISHES*

### **TINTCOAT**

A premium 2-layer paint application with the addition of a tinted clearcoat, lending the finish an extra depth and brightness.

### **TRICOAT**

A meticulous 3-layer process that results in a dramatic hue-shifting color.

ESCALADE FAMILY

ESCALADE

HYBRID

ESV

EXT

PERFORMANCE

SAFETY TECHNOLOGY

COLLECTIONS

**COLOR**

WHEELS

SPECS

*Ebony Nuance Leather with Ebony Accents*



*Ebony Aniline Full Leather with Ebony Accents<sup>1</sup>*



1. Not available on EXT

# ALADE INTERIOR CHOICES

[BUILD YOUR OWN >>](#)

[LOCATE A DEALER >>](#)

*Cashmere Nuance Leather with Cocoa Accents*



*Cocoa Aniline Full Leather with Very Light Linen Accents<sup>1</sup>*





**22" 7-SPOKE ULTRA-  
BRIGHT MACHINED-FINISH  
ALUMINUM WHEELS WITH  
PAINTED ACCENTS**

Standard on Escalade and  
Escalade ESV Premium  
Collection and includes  
P285/45R22 all-season tires



# ESCALADE WHEEL CHOICES

[BUILD YOUR OWN >>](#)

[LOCATE A DEALER >>](#)



## ***22" 7-SPOKE CHROMED ALUMINUM WHEELS***

Standard on Luxury Collection, EXT Premium and Hybrid and includes P285/45R22 all-season tires



## ***18" 7-SPOKE ALUMINUM WHEELS WITH MACHINED FINISH***

Standard on Escalade and includes P265/65R18 all-season tires



## ***22" 7-SPOKE CHROMED ALUMINUM WHEELS***

Standard on Platinum Edition and includes P285/45R22 all-season tires

## ESCALADE

CAPACITIES	
	Maximum payload <sup>1</sup> /trailer weight <sup>2</sup>
RWD	1,573 lbs./8,300 lbs.
AWD	1,582 lbs./8,100 lbs.

MAXIMUM CARGO AREA <sup>3</sup>	
Volume	
	108.9 cu. ft.

## ESCALADE HYBRID

CAPACITIES	
	Maximum payload <sup>1</sup> /trailer weight <sup>2</sup>
RWD	1,415 lbs./5,800 lbs.
AWD	1,358 lbs./5,600 lbs.

MAXIMUM CARGO AREA <sup>3</sup>	
Volume	
	108.9 cu. ft.

## ESCALADE ESV

CAPACITIES	
	Maximum payload <sup>1</sup> /trailer weight <sup>2</sup>
RWD	1,413 lbs./8,000 lbs.
AWD	1,418 lbs./7,700 lbs.

MAXIMUM CARGO AREA <sup>3</sup>	
Volume	
	137.4 cu. ft.

## ESCALADE EXT

CAPACITY	
	Maximum payload <sup>1</sup> /trailer weight <sup>2</sup>
AWD	1,239 lbs./7,600 lbs.

CARGO AREA DIMENSIONS <sup>3</sup>	
Height	25.0"
Length with Midgate up	63.0"
Length with Midgate down	97.6"
Width	50.0"
Cargo volume, bed only	45.5 cu. ft.
Cargo volume, <sup>4</sup> with Midgate down and tonneau covers installed	101.0 cu. ft.

1. Maximum payload capacity includes weight of driver, passengers, optional equipment and cargo.

2. Maximum trailer-weight ratings are calculated assuming a base vehicle, except for any option(s) necessary to achieve the rating, plus driver.

The weight of other optional equipment, passengers and cargo will reduce the maximum trailer weight your vehicle can tow. See your Cadillac dealer for additional details.

3. Cargo and load capacity limited by weight and distribution.

4. Cargo volume measured behind first-row seating with second-row seats folded.



68.2"  
79.0"



Wheelbase: 116.0"  
Length: 202.5"



75.9"

67.0"

[BUILD YOUR OWN >>](#)

[LOCATE A DEALER >>](#)



68.2"  
79.1"



Wheelbase: 130.0"  
Length: 222.9"



75.5"

67.0"

[BUILD YOUR OWN >>](#)

[LOCATE A DEALER >>](#)



68.2"  
79.1"



Wheelbase: 130.0"  
Length: 222.0"



75.5"

67.0"

[BUILD YOUR OWN >>](#)

[LOCATE A DEALER >>](#)

## ***THE STANDARD OF THE WORLD AT YOUR FINGERTIPS***

We set out to create our own uniquely American breed of extraordinary. Each built with tenacity, a refusal to leave well enough alone. From dramatic designs to world-class performance, we're setting the standard. To stay current, we invite you to sign up for our monthly eNewsletter. You'll receive invitations to exclusive events, the latest product news and information and launch updates.

**SIGN UP >>**





ESCALADE FAMILY

ESCALADE

HYBRID

ESV

EXT

PERFORMANCE

SAFETY TECHNOLOGY

COLLECTIONS

COLOR

WHEELS

SPECS

## ABOUT THIS DIGITAL CATALOG

We have tried to make the information presented comprehensive and factual. We reserve the right, however, to make changes at any time, without notice, in prices, colors, materials, equipment, specifications, models and availability. Specifications, dimensions, measurements, ratings and other numbers presented here and in printed materials provided at the dealership or affixed to vehicles are approximates, based upon design and engineering drawings and prototypes and laboratory tests. Your vehicle may differ due to variations in manufacture and equipment. Since some information may have been recently updated, please check with your Cadillac dealer for complete details. Cadillac reserves the right to lengthen or shorten the model year for any product for any reason, or to start and end model years at different times. Note: Some photographs show vehicles with optional equipment.

**ONSTAR** OnStar services require vehicle electrical system (including battery), wireless service and GPS satellite signals to be available and operating for features to function properly. OnStar acts as a link to existing emergency service providers. Subscription Service Agreement required. Call 1-888-4ONSTAR (466-7827) or visit [onstar.com](http://onstar.com) for OnStar's Terms and Conditions, Privacy Policy and details and system limitations.

**ENGINES** Cadillac products are equipped with engines produced by GM Powertrain or suppliers to GM worldwide. The engines in Cadillac products may also be used in other GM makes or models.

## TIRE SEALANT AND COMPRESSOR KIT

If your vehicle has a tire sealant and compressor kit, it uses a liquid tire sealant to temporarily seal up to a 1/4-inch puncture in the tread area of the tire. After using the inflator kit, it is recommended to take the tire to an authorized dealer for inspection and repair as soon as possible but at least within 100 miles of driving. The tire sealant cannot seal and inflate sidewall damage, punctures larger than 1/4 inch, or a tire that has unseated from the wheel. The sealant can only be used on one tire one time before its expiration date.

**ASSEMBLY** Cadillac vehicles and their components are assembled or produced by different operating units of General Motors, its subsidiaries or suppliers to GM worldwide. We sometimes find it necessary to produce Cadillac vehicles with different or differently sourced components than originally scheduled. Since some options may be unavailable when your vehicle is assembled, we suggest that you verify that your vehicle includes the equipment you ordered or, if there are changes, that they are acceptable to you.

## UPDATED SERVICE INFORMATION

Cadillac dealers receive useful service bulletins about Cadillac products. You may purchase them from Helm Incorporated by calling 1-800-551-4123 or by visiting [www.helminc.com](http://www.helminc.com).

## NEW-VEHICLE LIMITED WARRANTY

World-class coverage comes standard on every 2013 Cadillac. This warranty is for Cadillac vehicles registered in the U.S.A. See your Cadillac dealer for terms and conditions.

### COVERED FOR 6 YEARS/70,000 MILES (WHICHEVER COMES FIRST)

Powertrain Limited Warranty with no deductible, Roadside Assistance Program,<sup>1</sup> Courtesy Transportation Program<sup>1</sup>

### COVERED FOR 4 YEARS/50,000 MILES (WHICHEVER COMES FIRST)

Bumper-to-Bumper coverage; Tires—Defects in material and workmanship; Repairs made to correct any vehicle defect; Corrosion on body sheet metal panels.

**RUST THROUGH PROTECTION** Cadillac vehicles are designed and built to resist corrosion and rust-through corrosion. Any body sheet metal that rusts through (in the form of an actual hole in the sheet metal) is covered for six years unlimited mileage.

Cosmetic or surface corrosion, resulting from stone chips or scratches in the paint, for example, is not included in the Rust Through coverage. Application of additional rust-inhibiting materials is not required under the Rust Through coverage and none is recommended. See your Cadillac dealer for terms of this limited warranty.

**FLEET ORDERS** Some standard content may be deleted with fleet orders. See dealer for details.

## AN IMPORTANT NOTE ABOUT ALTERATIONS AND WARRANTIES

Installations or alterations to the original equipment vehicle (or chassis) as distributed by General Motors are not covered by the General Motors New-Vehicle Limited Warranty. The special body company, assembler, equipment installer or upfitter is solely responsible for warranties on the body or equipment and any alterations (or any effect of the alterations) to any of the parts, components, systems or assemblies installed by GM. General Motors is not responsible for the safety or quality of design features, material or workmanship of any alterations by such suppliers.

1. Roadside Assistance Program and Courtesy Transportation Program are not a part of the New Vehicle Limited Warranty. A separate booklet entitled "Warranty and Owner Assistance Information" furnished with each new vehicle provides detailed warranty coverage information.

GM, the GM emblem, Cadillac, the Cadillac badge, OnStar, the OnStar emblem and the slogans, emblems, vehicle model names, vehicle body designs and other marks appearing in this catalog are the trademarks and/or service marks of General Motors, its subsidiaries, affiliates or licensors. iPod is a registered trademark of Apple, Inc.

©2012 General Motors. All rights reserved.

*cadillac.com/escalade*